



Ridge Cap Shingles

Installed on the hip and ridge areas of a home to help provide maximum protection

- Accentuate the Natural Beauty... Of your newly installed shingle roof
- Protect... Guard against leaks and blow-offs at the hip and ridge areas of your roof
- The Right Colors... Designed to complement the color of your roof's shingles (unlike cut-up 3-tab shingles)
- Peace Of Mind... Up to a Lifetime Ltd. warranty when installed on Lifetime Shingle roofs¹



U.S. only

¹ See GAF Shingle & Accessory Ltd. Warranty for complete coverage and restrictions. The word "Lifetime" refers to the length of coverage provided by the GAF Shingle & Accessory Ltd. Warranty and means as long as the original individual owner(s) of a single-family detached residence [or the second owner(s) in certain circumstances] owns the property where the shingles and accessories are installed. For owners/structures not meeting the above criteria, Lifetime coverage is not applicable. Lifetime Ltd. warranty on accessories requires the use of at least three qualifying GAF accessories and the use of Lifetime Shingles.

² Periodically tested by independent and internal labs to ensure compliance with ASTM D3462 at time of manufacture.

³ See GAF Shingle & Accessory Ltd. Warranty for complete coverage and restrictions.

These products are not available in all areas. See www.gaf.com/ridgecapavailability for details.

Where They Fit Within The Lifetime Roofing System

1. Lifetime Shingles
2. Leak Barrier
3. Starter Strip Shingles
4. Roof Deck Protection
5. Cobra® Attic Ventilation
6. Ridge Cap Shingles

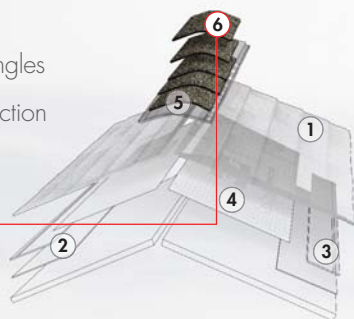

TIMBERTEX®

Premium Ridge Cap Shingles

SPECIFICATIONS

- Fiberglass asphalt design with double-layer construction
- Available in 12" (305 mm) width
- 8" (203 mm) exposure
- UL Listed to ANSI/UL 790 Class A
- Meets ASTM D3161 Class F; ASTM D3018 Type I; and ASTM D3462²
- Miami-Dade County Product Control approved
- CSA A123.5
- Florida Building Code approved
- ICC-ES ESR-1475 and ICC-ES ESR-3267
- 150 pieces per 100 lineal ft. (30 lm); 5 bundles per 100 lineal ft. (30 lm)
- Approx. 2 nails per piece
- Up to a Lifetime Ltd. warranty when installed on Lifetime Shingle roofs¹





RIDGLASS®

Premium Ridge Cap Shingles

SPECIFICATIONS

- Fiberglass SBS polymer-modified asphalt design
- Available in 8" (203 mm) and 10" (254 mm) widths
- 8" (203 mm) exposure
- Meets ASTM D3161 Class A; ASTM D3018 Type I; and ASTM D3462²
- UL Listed to ANSI/UL 790 Class A
- CSA A123.5
- ICC-ES ESR-1475 and ICC-ES ESR-3267
- 48 (8" [203 mm] & 10" [254 mm]) pcs./box (one box covers 31 lineal ft. [9 lm] of finished hip & ridge); 3.2 boxes cover approx. 100 lineal ft. (30 lm)
- Approx. 2 nails per piece
- Up to a Lifetime ltd. warranty when installed on Lifetime Shingle roofs¹



SEAL-A-RIDGE®

Protective Ridge Cap Shingles

SPECIFICATIONS

(Standard Seal-A-Ridge® Ridge Cap Shingles)

- Fiberglass asphalt design
- 6 2/3" (169 mm) exposure
- Approx. 12" (305 mm) wide
- UL Listed to ANSI/UL 790 Class A
- Miami-Dade County Product Control approved
- Florida Building Code approved
- Meets ASTM D3462²
- ICC-ES ESR-1475 and ICC-ES ESR-3267
- 4 bundles cover approx. 100 lineal feet (30 lm)
- Approx. 2 nails per piece
- Up to a Lifetime ltd. warranty when installed on Lifetime Shingle roofs¹

SPECIFICATIONS

(Seal-A-Ridge® ArmorShield™ SBS Modified IR Ridge Cap Shingles)

- Fiberglass SBS modified asphalt design
- UL 2218 Class 4 impact resistant
- 5" (127 mm) exposure
- Approx. 12" (305 mm) wide
- UL Listed to ANSI/UL 790 Class A
- Meets ASTM D3462²
- ICC-ES ESR-1475 and ICC-ES ESR-3267
- 4 bundles cover approx. 100 lineal feet (30 lm)
- Approx. 2 nails per piece
- Up to a Lifetime ltd. warranty when installed on Lifetime Shingle roofs¹



Z[®] RIDGE

Distinctive Ridge Cap Shingles

SPECIFICATIONS

- Fiberglass asphalt design
- 5 5/8" (143 mm) exposure
- Approx. 10" (254 mm) wide
- UL Listed to ANSI/UL 790 Class A
- Meets ASTM D3018 Type I, ASTM D3161 Class A, and ASTM D3462²
- ICC-ES ESR-1475 and ICC-ES ESR-3267
- 3 bundles cover approx. 100 lineal feet (30 lm)
- Up to a Lifetime ltd. warranty when installed on Lifetime Shingle roofs¹

Only available in the U.S.

^{1,2,3} See footnotes on previous page



Roof Deck Protection

Helps guard against wind-driven rain and keep your roof system dry

- **An Extra Layer of Protection...** Between your shingles and your roof deck
- **Helps Prevent Wind-Driven Rain...** (Or water from other sources) from infiltrating under your shingles and causing damage to your roof structure or the inside of your home
- **Lies Flatter...** Helps avoid buckling when installed for a better-looking finished roof
- **Helps Reduce Blow-off...** By allowing your shingles to lie flatter and more uniformly
- **Peace of Mind...** Up to a Lifetime Ltd. warranty when installed on Lifetime Shingle roofs†



U.S. only

† See GAF Shingle & Accessory Ltd. Warranty for complete coverage and restrictions. The word "Lifetime" refers to the length of coverage provided by the GAF Shingle & Accessory Ltd. Warranty and means as long as the original individual owner(s) of a single-family detached residence [or the second owner(s) in certain circumstances] owns the property where the shingles and accessories are installed. For owners/structures not meeting the above criteria, Lifetime coverage is not applicable. Lifetime Ltd. warranty on accessories requires the use of at least three qualifying GAF accessories and the use of Lifetime Shingles.

Where They Fit Within The Lifetime Roofing System

1. Lifetime Shingles
2. Leak Barrier
3. Starter Strip Shingles
4. **Roof Deck Protection**
5. Cobra® Attic Ventilation
6. Ridge Cap Shingles

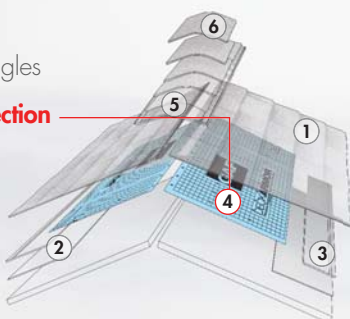

DECKARMOR™

Premium **Breathable** Roof Deck Protection



- **Revolutionary "Breathable" Technology...** Helps reduce moisture in the roofing system that can cause mold, mildew, and expensive structural damage
- **Enhanced Walkability...** Specially designed surface helps provide enhanced walkability for installers compared to conventional felts or typical synthetic underlayments
- **Premium Construction...** Exceptionally durable, non-asphaltic construction will not rot or become brittle (unlike conventional asphaltic felts, which can disintegrate over time)
- **Exceptionally Strong...** At least 600% greater tear strength than standard #30 felt¹
- **Looks Better...** Unlike conventional asphaltic felts, Deck-Armor™ resists wrinkling or buckling, so it lets your shingles lie flatter for a better-looking roof

¹ GAF trapezoidal tear strength (lbs) testing per ASTM D4533.

SPECIFICATIONS

- UV-stabilized polypropylene construction resists UV degradation for up to 180 days*
- Meets or exceeds the physical requirements of ASTM D226 and D4869
- Miami-Dade County Product Control and Florida Building Code approved
- ICC-ES ESR-2808
- Approx: 10 squares (1,000 ft² [92.9 m²])/roll (excludes laps); length 223' (68 m); width 54" (1.4 m); 37 lb. (17 kg)/roll (nominal)
- Listed with Texas Department of Insurance as an acceptable alternate roof underlayment

Note: **Always** use plastic cap nails or staples with plastic caps to install Deck-Armor™ Roof Deck Protection. Do **NOT** use nails or staples without caps.

Deck-Armor™ "Out-breathes" the competition!



As measured on Mocon unit @ 23°C and 50% R.H. by GAF



SHINGLE-MATE®

Roof Deck Protection

- Fiberglass reinforced, so it lies flatter than typical asphalt felts for a better-looking roof
- UL Listed to ANSI/UL 790 Class A when used with UL Class A roof coverings
- Miami-Dade County Product Control and Florida Building Code approved
- Meets the physical requirements of ASTM D226 and ASTM D4869
- Approx: 4 squares/roll (432 ft² [40.13 m²]); length 144' (43.89 m); width 36" (914 mm); 30 lb. (13.6 kg)/roll

*See footnote on next page

TIGERPAW™

Roof Deck Protection



- **Excellent Walkability...** Specially designed surface helps provide excellent walkability for installers compared to conventional felts or typical synthetic underlayments
- **Moisture-Control Design...** Helps remove nearly twice as much damaging moisture from your roof deck as the leading synthetic non-breathable underlayment¹
- **Durable Construction...** Non-asphaltic, polypropylene construction will not rot or become brittle (unlike conventional felts, which can disintegrate over time)
- **Better-Looking Roof...** Unlike conventional asphaltic felts, Tiger Paw™ Roof Deck Protection resists wrinkling and buckling that can “telegraph” through your roof shingles and detract from its finished appearance
- **Stronger...** Synthetic, non-woven construction provides at least 600% greater tear strength than standard #30 felt²

¹ As per GAF ASTM D570-modified testing.
² GAF trapezoidal tear strength (lbs) testing per ASTM D4533.

SPECIFICATIONS

- UV-stabilized polypropylene construction resists UV degradation for up to 180 days*
- Meets or exceeds the physical requirements of ASTM D226, D4869, and CSA A220-1
- Miami-Dade County Product Control and Florida Building Code approved
- ICC-ES ESR-3286
- Approx: 10 squares (1,000 ft² [92.9 m²])/roll (excludes laps); length 250' (76.2 m); width 48" (1.22 m); 40 lb. (18 kg)/roll (nominal)
- Listed with Texas Department of Insurance as an acceptable alternate roof underlayment

Note: **Always** use plastic cap nails or staples with plastic caps to install Tiger Paw™ Roof Deck Protection. Do **NOT** use nails or staples without caps.

*Note: 180-day UV resistance refers to standardized testing conducted by GAF to ensure the product will not physically degrade when exposed to UV. It is **NOT** related to withstanding water, snow, or wind. While Deck-Armor™ and Tiger Paw™ Roof Deck Protection are water resistant, they are **NOT WATERPROOF. DO NOT USE** Deck-Armor™ or Tiger Paw™ Roof Deck Protection as a temporary roof to protect property or possessions.

FELTBUSTER®

HIGH-TRACTION SYNTHETIC ROOFING FELT



- **Enhanced Walkability...** Special spunbound surface helps provide increased traction compared to typical asphalt felts
- **Tough Synthetic Construction...** Resists tearing and will not absorb moisture, become brittle, or leach oils
- **Easy to Work With...** Super-lightweight, 10 square, 48" (1.23 m) wide roll (vs. typical 36" [914 mm] wide felt rolls)
- **Cooler to Work On...** Medium-gray surface is cooler than typical black asphalt felts and the leading black low-cost synthetic underlayment

SPECIFICATIONS

- UV-stabilized polypropylene construction resists UV degradation for up to 90 days**
- For use with asphalt shingles
- Meets or exceeds the physical requirements of ASTM D226, D4869, and CSA A123-3
- Miami-Dade County Product Control and Florida Building Code approved
- Approx: 10 squares/roll – 1,000 sq. ft. (92.9 m²) (excludes laps); length 250' (76.2 m); width 48" (1.22 m); 23 lb. (10.4 kg) / roll (nominal)
- Listed with Texas Department of Insurance as an acceptable alternate roof underlayment

Note: **Always** install FeltBuster® High-Traction Synthetic Roofing Felt using plastic cap nails or plastic cap staples. Do **NOT** use nails or staples without caps.

Note: 90-day UV resistance refers to standardized testing conducted by GAF to ensure the product will not physically degrade when exposed to UV. It is **NOT related to withstanding water, snow, or wind. While FeltBuster® High-Traction Synthetic Roofing Felt is water resistant, it is **NOT WATERPROOF. DO NOT USE** FeltBuster® High-Traction Synthetic Roofing Felt as a temporary roof to protect property or possessions.



VERSASHIELD®

FIRE-RESISTANT ROOF DECK PROTECTION

(Available across the U.S.; not available in Canada)

- The best protection against fire spread and penetration
- Fiberglass reinforced, so it lies flatter than typical asphalt felts for a better-looking roof
- Will upgrade the UL fire classification of almost any type of roof (refer to UL Certifications Directory for actual assemblies)
- Meets or exceeds ASTM D226 Type II, D4869 Type IV, and D6757 Type I or Type II
- Approx: 3.5 squares/roll (350 ft² [32.5 m²]) (excludes laps); length 100' (30.5 m); width 42" (1,067 mm); 52.5 lb. (24 kg)/roll
- Miami-Dade County Product Control and Florida Building Code approved
- ICC-ES ESR-2053
- Listed with Texas Department of Insurance as an acceptable alternate roof underlayment



ROOFPRO™

SBS-Modified All-Purpose Underlayment

(Available in Western U.S. only)

- SBS-modified asphalt increases flexibility and provides long-lasting durability; up to 60 days' UV exposure resistance***
- Fiberglass reinforced, so it lies flatter than typical asphalt felts for a better-looking roof
- UL Listed to ANSI/UL 790 Class A when used with UL Class A roof coverings
- Meets or exceeds all physical properties of ASTM D226
- UL ER10689-01 Evaluation Report
- Approx: 2 squares/roll (216 gross ft² [20.1 m²]); length 65.8' (20.1 m); width 39.4" (1 m)

***Note: 60-day UV resistance refers to standardized testing conducted by GAF to ensure the product will not physically degrade when exposed to UV. It is **NOT** related to withstanding water, snow, or wind. While RoofPro™ SBS-Modified All-Purpose Underlayment is water resistant, it is **NOT WATERPROOF. DO NOT USE** RoofPro™ SBS-Modified All-Purpose Underlayment as a temporary roof to protect property or possessions.



Leak Barriers

Provides exceptional protection against leaks caused by roof settling and extreme weather

- **Protect Your Property...** Help prevent wind-driven rain from leaking through the roof deck, or melting ice and snow (caused by ice dams in harsh winter climates) from leaking into property's interior
- **Add Extra Protection...** In valleys and at eave and rake edges—the most leak-prone areas of the roof. Strongly recommended for other areas like skylights, dormers, vent pipes, chimneys, and other flashing areas
- **Help Avoid Costly Repairs...** Due to staining on interior walls and ceilings from leaks
- **Peace Of Mind...** Up to a Lifetime Ltd. warranty when installed on Lifetime Shingle roofs†



† See GAF Shingle & Accessory Ltd. Warranty for complete coverage and restrictions. The word "Lifetime" refers to the length of coverage provided by the GAF Shingle & Accessory Ltd. Warranty and means as long as the original individual owner(s) of a single-family detached residence [or the second owner(s) in certain circumstances] owns the property where the shingles and accessories are installed. For owners/structures not meeting the above criteria, Lifetime coverage is not applicable. Lifetime Ltd. warranty on accessories requires the use of at least three qualifying GAF accessories and the use of Lifetime Shingles.

Where They Fit Within The Lifetime Roofing System

1. Lifetime Shingles
2. **Leak Barrier**
3. Starter Strip Shingles
4. Roof Deck Protection
5. Cobra® Attic Ventilation
6. Ridge Cap Shingles

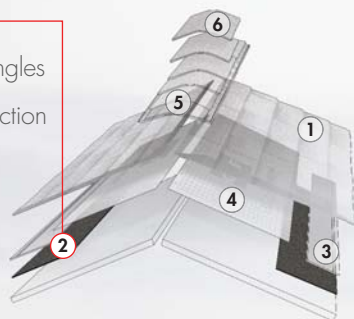

"Protect Your Investment And Safeguard Vulnerable Areas"

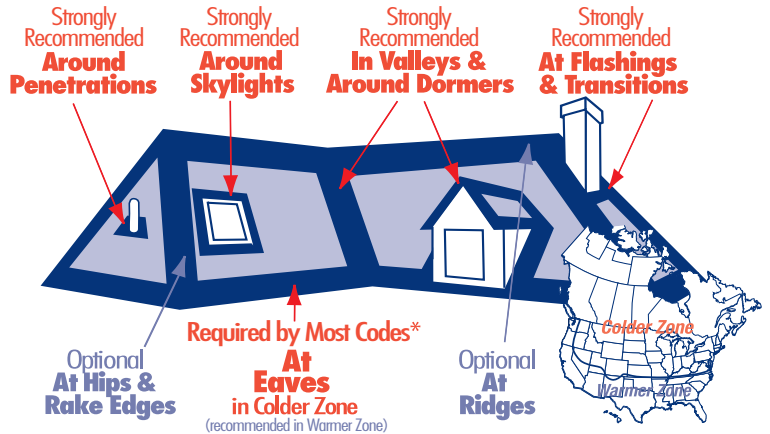

*Check local building codes for specifications in your area.



SPECIFICATIONS (NOM.)

WEATHERWATCH® Mineral-Surfaced Leak Barrier

(For Shingle Roofs)

- Mineral surface & fiberglass reinforced
- Split-back release film
- UL Listed to ANSI/UL 790 Class A
- ICC Evaluation Report ESR-1322
- Meets the performance criteria of ASTM D1970
- Miami-Dade County Product Control approved
- State of Florida approved
- Roll width is 36" (0.9 m)
- Available in 1.5 & 2.0 square rolls
- Length of 1.5 square roll is 50' (15.2 m)
- Length of 2.0 square roll is 66.8' (20.3 m)
- Approx. area of 1.5 square roll is 150 ft² (13.9 sq m)
- Approx. area of 2.0 square roll is 200 ft² (18.6 sq m)

STORMGUARD® Film-Surfaced Leak Barrier

(For Shingle And Metal Roofs)

- Film surface & fiberglass reinforced
- Split-back release film
- UL Listed to ANSI/UL 790 Class A
- ICC Evaluation Report ESR-1322
- Meets the performance criteria of ASTM D1970
- Miami-Dade County Product Control approved
- State of Florida approved
- Available in 2.0 square rolls
- Width is 36" (0.9 m), length is 66.8' (20.3 m)
- Approx. area of 2.0 square roll is 200 ft² (18.6 sq m)



Eave/Rake Starter Strips

Help prevent shingle blow-off and reduce waste

- Placed at the eaves... To help prevent shingle blow-off
- Save Labor... Provides a cost-effective alternative to using cut-up shingles as your starter strip
- Help Prevent Blow-Offs... Includes a high-quality, properly positioned factory-applied adhesive that will tightly lock your shingles in place
- Easy To Install... Pre-scored (Pro-Start® & WeatherBlocker™ only); no cutting needed
- Maximum Wind Warranties... Requires starter strips on rake and eaves†
- Peace Of Mind... Up to a Lifetime Ltd. warranty when installed on Lifetime Shingle roofs†



* Periodically tested by independent and internal labs to ensure compliance with ASTM D3462 at time of manufacture.

† See GAF Shingle & Accessory Ltd. Warranty for complete coverage and restrictions. The word "Lifetime" refers to the length of coverage provided by the GAF Shingle & Accessory Ltd. Warranty and means as long as the original individual owner(s) of a single-family detached residence (or the second owner(s) in certain circumstances) owns the property where the shingles and accessories are installed. For owners/structures not meeting the above criteria, Lifetime coverage is not applicable. Lifetime Ltd. warranty on accessories requires the use of at least three qualifying GAF accessories and the use of Lifetime Shingles.

Where They Fit Within The Lifetime Roofing System

1. Lifetime Shingles
2. Leak Barrier
3. Starter Strip Shingles
4. Roof Deck Protection
5. Cobra® Attic Ventilation
6. Ridge Cap Shingles

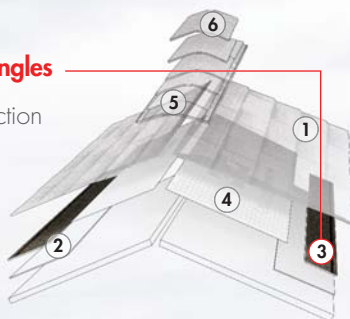

! Many warranties require starter strips on both eave and rake for maximum wind coverage

WEATHERBLOCKER™ PREMIUM EAVE/RAKE STARTER STRIP

(Use with all shingles. 17"x40" [432 x 1,016 mm] or splits to 8.5"x40" [216 x 1,016 mm])

- Meets ASTM D3462*
- UL Listed to ANSI/UL 790 Class A
- Available nationally
- Miami Dade County Product Control and Florida Building Code approved



PRO-START® EAVE/RAKE STARTER STRIP SHINGLES

(Use with most standard English and metric-sized shingles. 13"x38" [330 x 965 mm] or splits to 6.5"x38" [165 x 965 mm])

- Meets ASTM D3462*
- UL Listed to ANSI/UL 790 Class A
- Available nationally
- Miami Dade County Product Control and Florida Building Code approved

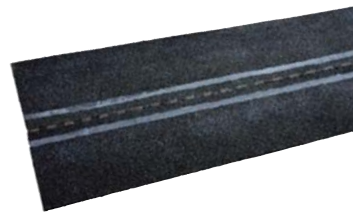

QUICKSTART® Peel & Stick Starter Roll

(Peel & Stick installation helps eliminate fastening and cutting of starters. For shingles with 6" [152 mm] or less exposure. 9' x 33' [227 mm x 10 m] roll.)

- Available nationally
- Florida Building Code approved
- Meets physical property requirements of ASTM D1970



Also Available:

STARTERMATCH™ STARTER STRIP SHINGLES

(Designed for use with GAF Lifetime Designer Shingles requiring complementary color starter. 13.25" x 40" [337 mm x 1,016 mm])



Cobra® Attic Ventilation

Helps to remove excess heat and moisture to protect your roof system and structure from premature deterioration

- Looks Terrific... Shingle-over design helps maintain an "uncluttered" look on your roof
- Promotes Energy Efficiency... By helping reduce excessive heat in your attic
- Durable Construction... Manufactured with tough, UV-stable materials for performance in virtually any climate
- Strong... Passes the 110 mph (177 km/h) wind-driven rain test (under controlled GAF laboratory testing)
- Peace of Mind... Up to a Lifetime Ltd. warranty when installed on Lifetime Shingle roofs†



U.S. only

† See GAF Shingle & Accessory Ltd. Warranty for complete coverage and restrictions. The word "Lifetime" refers to the length of coverage provided by the GAF Shingle & Accessory Ltd. Warranty and means as long as the original individual owner(s) of a single-family detached residence [or the second owner(s) in certain circumstances] owns the property where the shingles and accessories are installed. For owners/structures not meeting the above criteria, Lifetime coverage is not applicable. Lifetime Ltd. warranty on accessories requires the use of at least three qualifying GAF accessories and the use of Lifetime Shingles.

Where They Fit Within The Lifetime Roofing System

1. Lifetime Shingles
2. Leak Barrier
3. Starter Strip Shingles
4. Roof Deck Protection
5. Cobra® Attic Ventilation
6. Ridge Cap Shingles

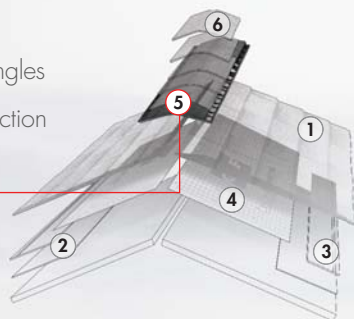

Choose From The Industry's

5 Styles To Choose From!



Product Name	Cobra® Exhaust Vent for Roof Ridge
Description & Availability	Roll-style vent, available in all climates
Net Free Ventilating Area (NFVA)	16.9 in ² (109 cm ²) (hand nail version) 14.1 in ² (91 cm ²) (nail gun version)
Width(s) Available	8" (203 mm) & 10.5" (267 mm); 11.75" (299 mm) metric
Nail-Gunable	Yes (nail gun version)
Length	20' (6.1 m) & 50' (15.24 m) rolls
Nails Included?	Yes
Hand Tearable?	No
Weather Filter?	N/A

Cobra® Ridge Vents...

- Provide excellent attic ventilation when properly installed with intake vents
- Work along the length of the roof's ridge to minimize temperature and equalize pressure inside the attic
- Allow a flow-through of fresh air to reduce damaging heat and moisture
- Include the EasyTear™ Sizing Feature, which allows you to hand-tear the vents in regular increments (except Cobra® Exhaust Vent For Roof Ridge)
- Up to a Lifetime Ltd. warranty when installed on Lifetime Shingle roofs†
- Carry a UL Class C fire rating, except Cobra® Exhaust Vent For Roof Ridge, which has a UL Class A rating
- ICC Evaluation Report ESR-1265
- Miami-Dade County Product Control approved
- Evaluated by Texas Department of Insurance

Most Comprehensive Line Of **Ridge Vents**!

	 (Only available in the U.S.)	 (Only available in the U.S.)	
Cobra Ridge Runner® Exhaust Vent for Roof Ridge	Cobra® Rigid Vent 3™ Exhaust Vent for Roof Ridge	Cobra® Snow Country™ Exhaust Vent for Roof Ridge	Cobra® Snow Country Advanced™ Exhaust Vent for Roof Ridge
Rigid roll-style vent, available in all climates	Premium rigid-style vent, available in warmer climates	Rigid-style vent, available in colder climates	Premium rigid-style vent, available in colder climates
12.5 in ² (81 cm ²)	18.0 in ² (116 cm ²)	18.0 in ² (116 cm ²)	18.0 in ² (116 cm ²)
11.5" (292 mm)	9" (229 mm) & 11.5" (292 mm)	11.5" (292 mm)	9" (229 mm) & 11.5" (292 mm)
Yes	No	No	No
20' roll (6.1 m)	4' sticks (1.21 m)	4' sticks (1.21 m)	4' sticks (1.21 m)
Yes	Yes	No	Yes
Yes	Yes	Yes	Yes
Yes	No	Yes	Yes

Specialty Solutions...

Cobra® HIPVENT Exhaust Vent for Hip Roofs

**Safe and effective attic exhaust ventilation
for roofs with little or no ridge**

- Unique Dual-Weather Fighter Filter™ helps resist all types of weather infiltration*
- Fully nail-gunable with included coil nails
- Size: 4' x 11.5" (1.21 m x 292.1 mm)
- NFA: 9 in² per lineal foot (58 cm²/lm)



Dual Weather Fighter Filter™

Cobra® INTAKEPRO Rooftop Intake Vent

**Provides critical intake ventilation for homes
with little or no soffits**

- Eliminates time consuming/expensive alterations at the soffit
- Fully nail-gunable with included coil nails
- Tested to resist wind-driven rain, snow and ice-dam infiltration*
- Size: 20' x 11" (6.1 m x 279 mm)
- NFA: 9 in² per lineal foot (58 cm²/lm)

*Under controlled GAF laboratory testing



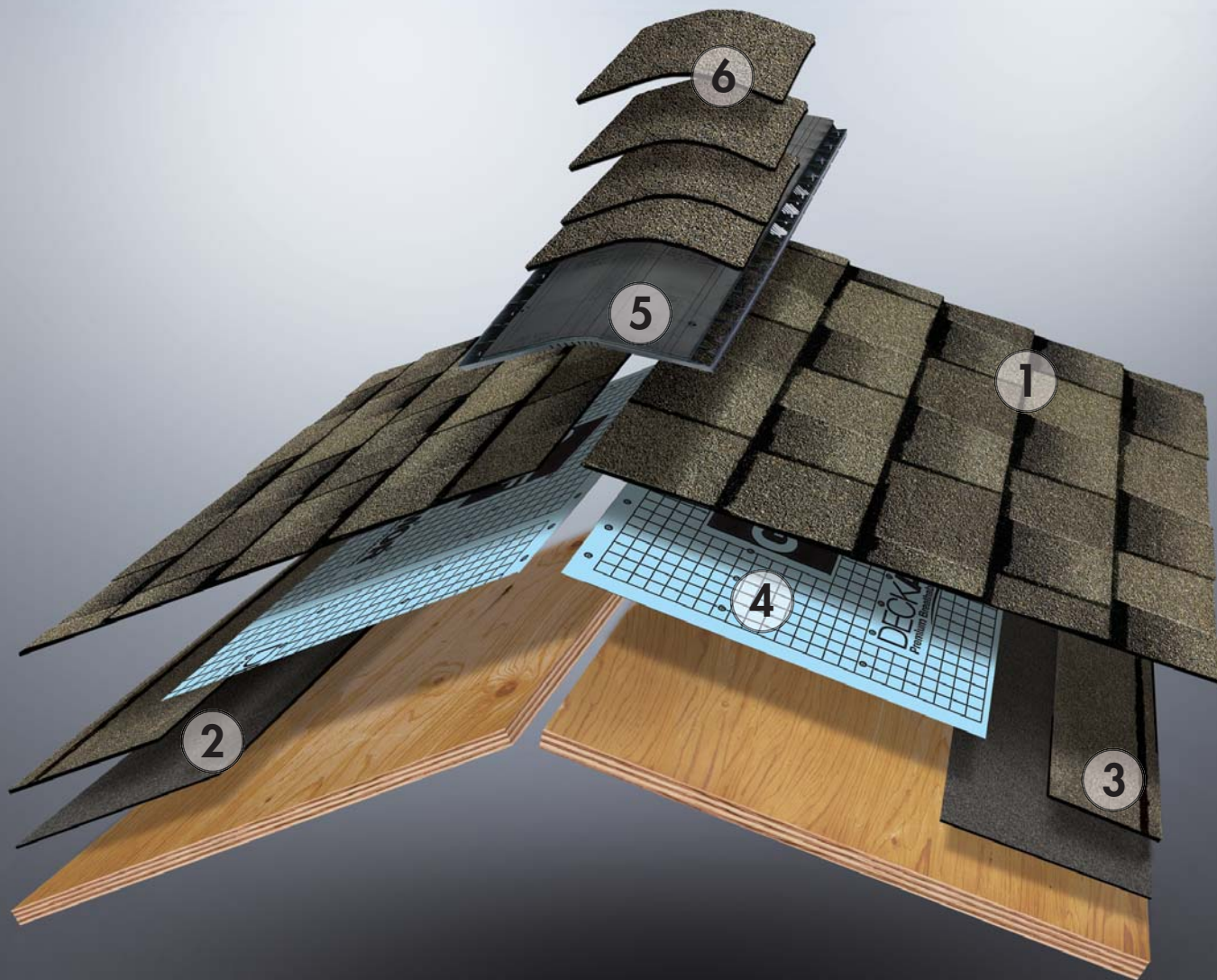

1 Lifetime[†] Shingles

GAF offers you many great Lifetime Shingle choices, including **Timberline[®]** Shingles with Advanced Protection[®] Shingle Technology. They're the #1-selling shingles in North America! Advanced Protection[®] Shingle Technology results in excellent protection for your home while reducing the use of precious natural resources. That's better for your home — and better for the environment!

To learn more about why Advanced Protection[®] Shingles are your best choice, visit gaf.com/APS/.

2 Leak Barrier

Provides excellent protection against leaks caused by roof settling and extreme weather. Ideal upgrade at all vulnerable areas (including at the eaves in the North*).



3 Starter Strip Shingles

Saves time, eliminates waste, and helps reduce risk of shingle blow-off...and may help qualify for upgraded wind warranty coverage (see *GAF Shingle & Accessory Ltd. Warranty* for details).



4 Roof Deck Protection

Provides a strong layer of protection against wind-driven rain and moisture infiltration.



The GAF Lifetime Roofing System has earned the prestigious Good Housekeeping Seal, which means that Good Housekeeping stands behind the products in this system. (Refer to Good Housekeeping Magazine for its consumer protection policy. Applicable in U.S. only.)

5 Cobra[®] Attic Ventilation

Helps remove excess heat and moisture from your attic to promote energy efficiency in your home and help extend the life of your roof.



6 Ridge Cap Shingles

Enhances the beauty of your home while helping guard against leaks at the hips and ridges.



*In the North, most building codes require the use of Leak Barrier at the eaves.

[†] See *GAF Shingle & Accessory Ltd. Warranty* for complete coverage and restrictions. The word "Lifetime" refers to the length of coverage provided by the *GAF Shingle & Accessory Ltd. Warranty* and means as long as the original individual owner(s) of a single-family detached residence (or the second owner(s) in certain circumstances) owns the property where the shingles and accessories are installed. For owners/structures not meeting the above criteria, Lifetime coverage is not applicable. Lifetime Ltd. warranty on accessories requires the use of at least three qualifying GAF accessories and the use of Lifetime Shingles.